

ASSEMBLY INSTRUCTION

HORACE

Office chair

ITEM CODE 69480

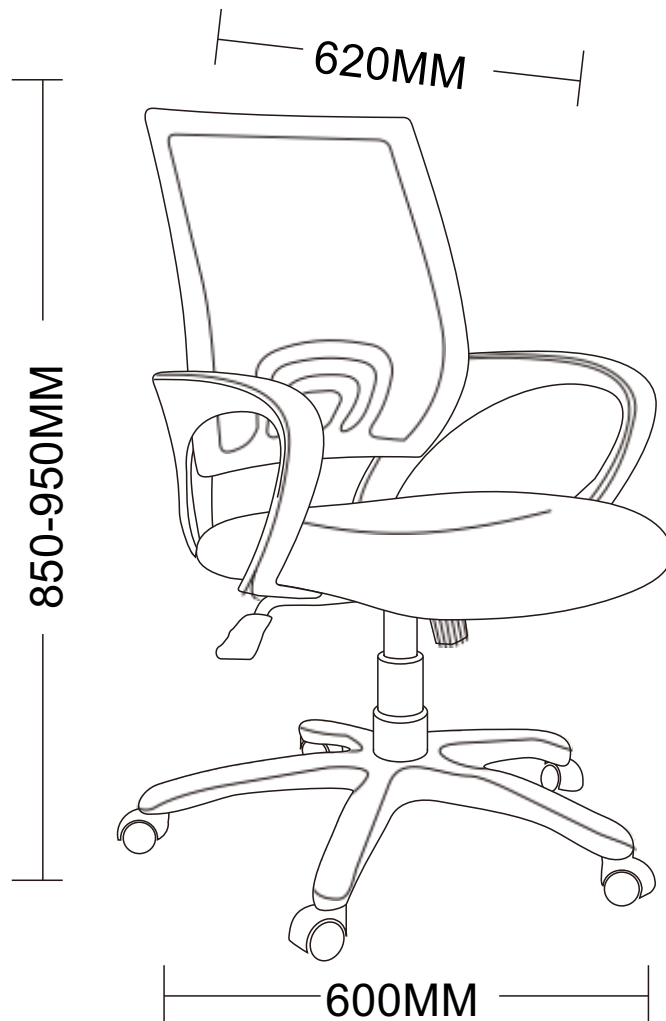



Imported by JWA Furniture Pty Ltd, Qld, Brisbane Australia.
For any assistance with assembly or for missing parts please refer to your receipt





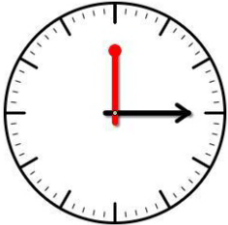

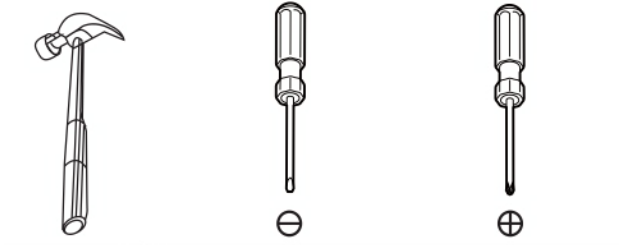
PRE-ASSEMBLY PREPARATION

Before you start:

1. Choose a clean, level, spacious assembly area. Avoid hard surfaces that may damage the product
2. Take care when lifting. Product should be assembled as near as possible to the point of use
3. Ensure that you have all required contents for complete assembly
4. Always read the assembly instructions carefully before beginning assembly.
5. Keep all hardware parts and packaging out of reach of small children.
6. Do not over tighten the screws and bolts as this may damage the threads
7. Assembly is to be carried out by a competent adult(s) ONLY
8. During assembly, children should be kept away from the product due to possible risk to injury.
9. Do not use this item if any components are missing or damaged.
10. Please keep the instructions for future reference.

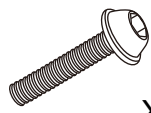
		
Allow 15 min	For 1 person	Additional tools required

PARTS LIST

<p>A</p>  <p>X4 M6x16mm</p>	<p>B</p>  <p>X2 M6x20mm</p>	<p>C</p>  <p>X4 M6x25mm</p>	<p>D</p>  <p>X2 M6x30mm</p>
<p>E</p>  <p>X4</p>	<p>F</p>  <p>X4 φ17Xφ8.5X1</p>	<p>G</p>  <p>X1</p>	

1	Back	5	Gas lift
2	Armrest	6	Three cups
3	Seat	7	Base
4	Mechanism	8	Caster



STEP 1: Insert caster 8 into base 7.

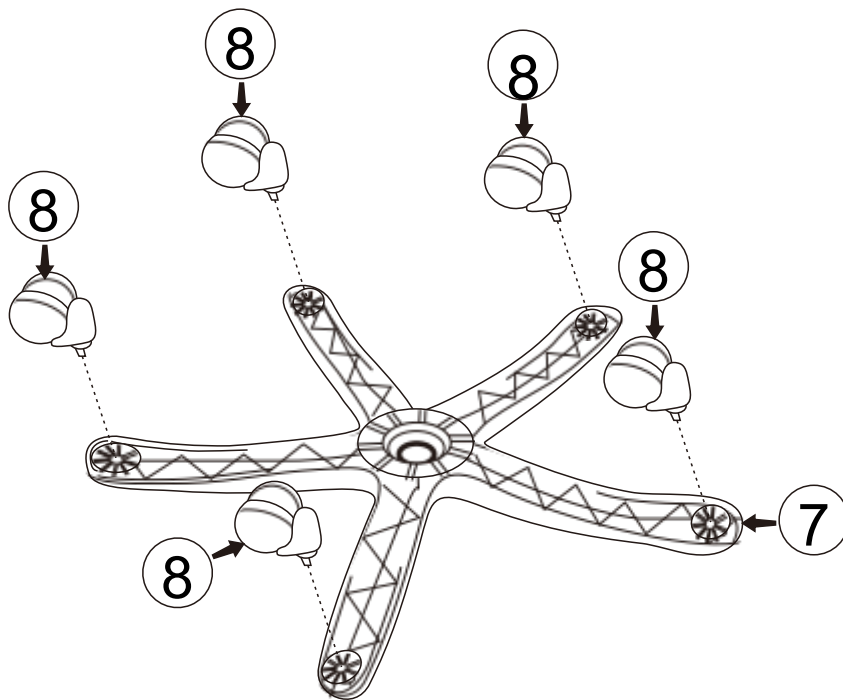

STEP2: Put gas lift 5 into base 7, and then put three cups of 6 in gas lift 5.

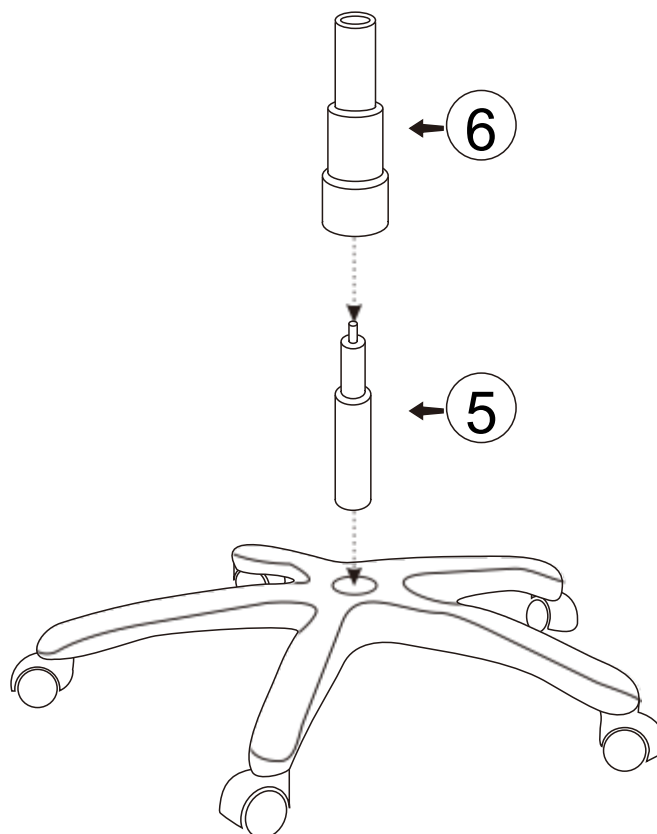

STEP 3: Connect armrest 2 to back 1 and twist in screws B and C with inner hexagon wrench G.

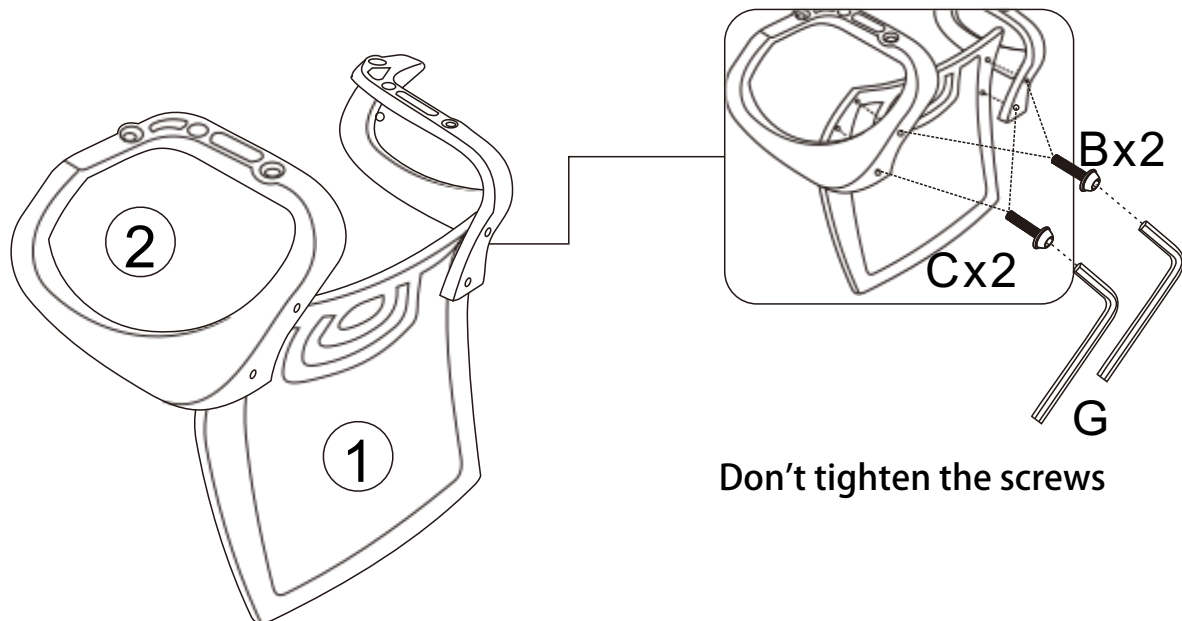

STEP 4: Connect mechanism 4 to seat 3 and twist screw A with an inner hexagon wrench G.

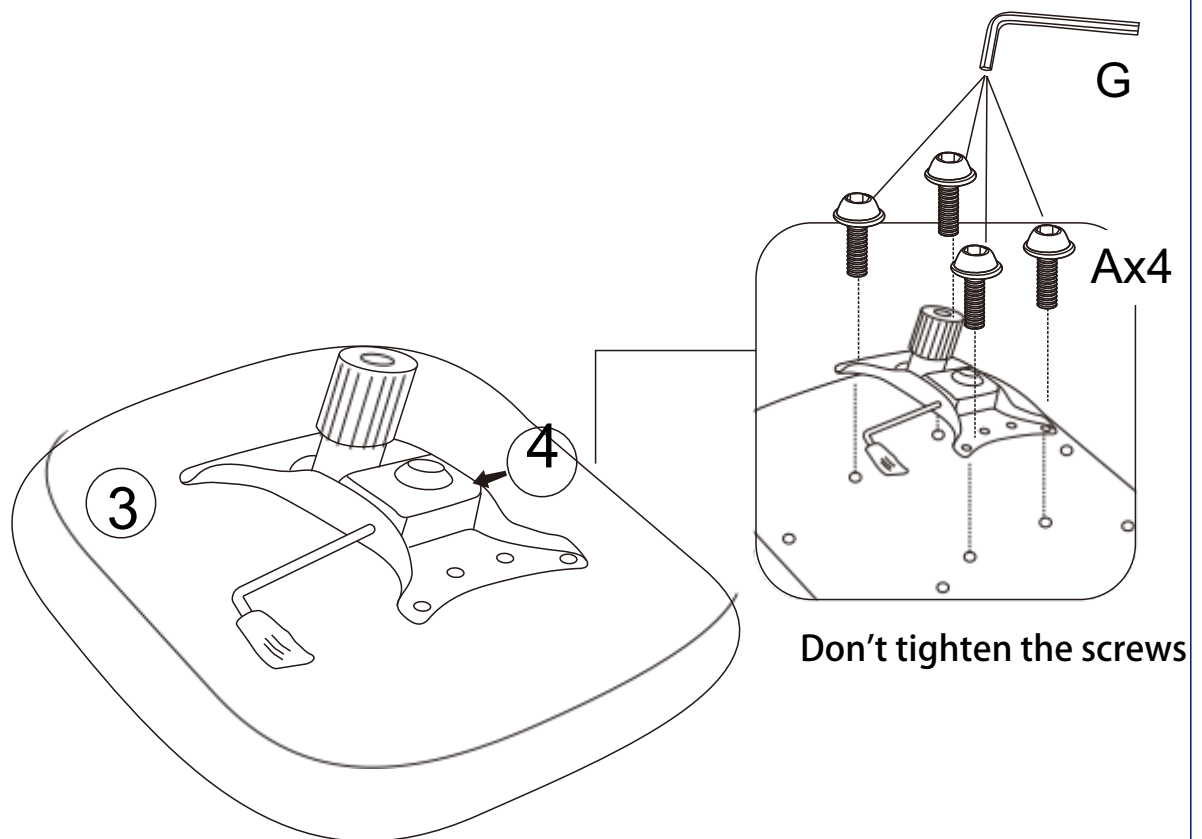

STEP 5: Connect armrest 2 to seat 3 and twist in screws C, D and gasket F with inner hexagon wrench G. Finally tighten all the screws.

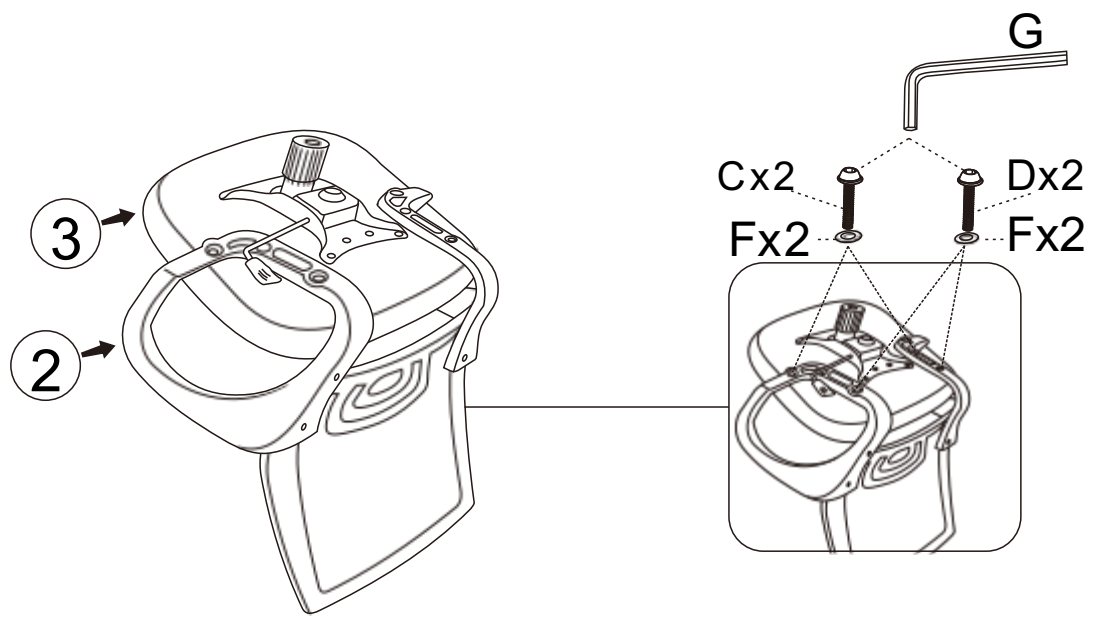

STEP 6: Press the rubber plug E into the armrest.

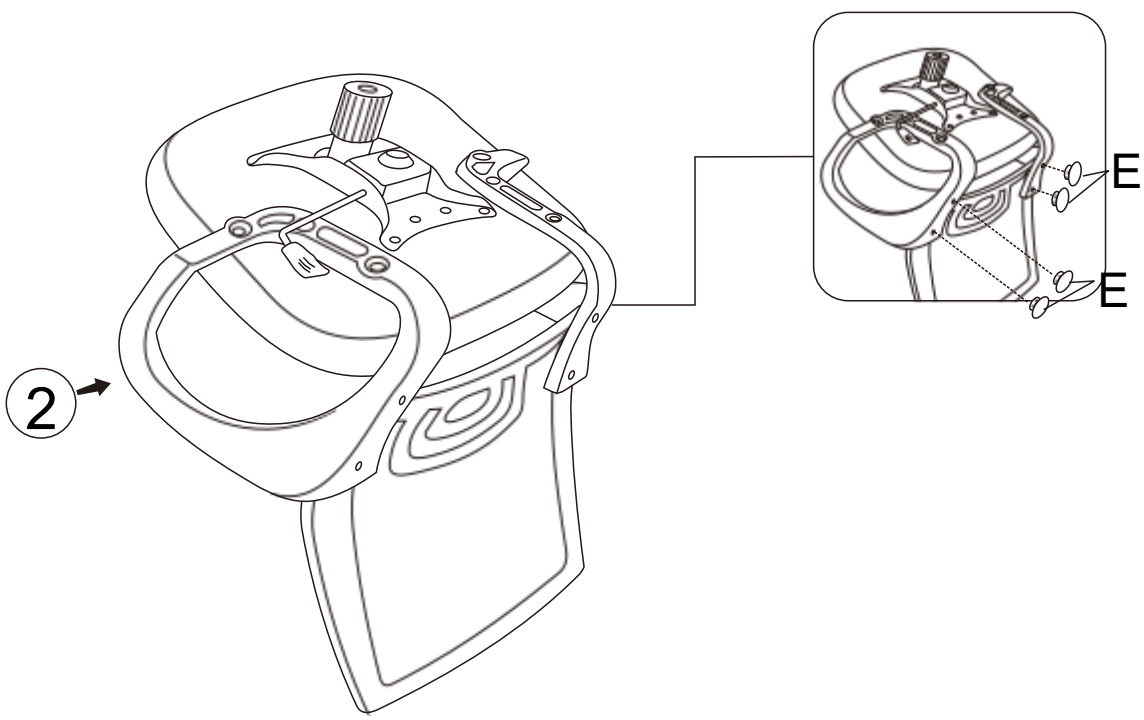

STEP 7: Place the mechanism 4 on gas lift 5.

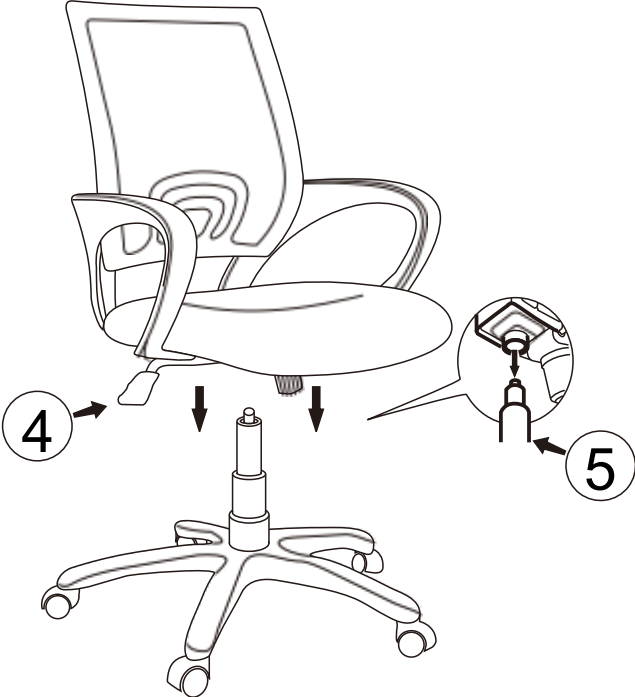

Complete the assembly.



WARNING

- DO NOT STAND ON THIS CHAIR-DO NOT USE THIS CHAIR AS STEP LADDER.
- USE THIS PRODUCT ONLY FOR SEATING ONE PERSON AT A TIME.
- DO NOT USE THIS CHAIR UNLESS ALL BOLTS, SCREWS AND KNOBS ARE FIRMLY SECURED.
- AT LEAST EVERY 4 MONTHS, CHECK ALL BOLTS, SCREWS AND KNOBS TO BE SURE THEY ARE TIGHT.
- IF PARTS ARE MISSING, BROKEN, DAMAGED OR WORN, STOP USE THE PRODUCT UNTIL REPAIRS ARE MADE. USING FACTORY AUTHORIZED PARTS.
- FAILURE TO FOLLOW THESE WARNINGS COULD RESULT IN SERIOUS INJURY.

CARE AND MAINTENANCE

REGULAR CARE:

Protect from direct sunlight
Vacuum regularly using low suction

CLEANING:

Do not wash, Do not dry clean, Do not shampoo clean
Clean only with hot water extraction machine. Professional cleaning recommended
Do not use dishwashing liquid or laundry detergent. Use only upholstery detergents
Do not wet filling
Dry in shade away from direct heat and sunlight
Allow to dry thoroughly before re-use

SPOT CLEANING:

Do not rub
Do not spot clean with any solvent
Treat spills and stains as soon as possible
Gently scrape off any soil or blot any liquid from the surface of the fabric before applying cleaner
Apply proprietary cleaning agents strictly according to instructions to remove the residue of the spill
Do not saturate the fabric or interior with water or other cleaning liquids

WARNING:

Apply only water-based soil resist (fabric protection) treatments. Do not use aerosol products

* PILLING IS NOT A FABRIC DEFECT OR FAULT AND IS NOT COVERED BY WARRANTY

* PILLING IS A NORMAL OCCURRENCE CAUSED BY WEAR AND TEAR AND DOES NOT AFFECT THE DURABILITY OR FUNCTIONALITY OF THE FABRIC AND IS EASILY REMOVED